

[6178]-7

E.E.

ENGINEERING MECHANICS
(2019 Pattern) (Semester - I) (101011)

Time : 2½ Hours]

[Max. Marks : 70

Instructions to the candidates:

- 1) Answer Q. 1 or Q. 2, Q. 3 or Q. 4, Q. 5 or Q. 6 and Q. 7 or Q. 8.
- 2) Neat sketches must be drawn wherever necessary.
- 3) Figures to the right indicate full marks.
- 4) Assume suitable data, if necessary.
- 5) Use of electronic pocket calculator is allowed.
- 6) Use of cell phone is prohibited in the examination hall.

- Q1)** a) A 1.5 m cable placed around a crate as shown in Fig. 1 a. If the mass of the crate is 300 kg, determine the tension in the cable. [7]
- b) A rectangular plate is supported horizontally by three cables at A, B and C as shown in Fig. 1 b. If weight of the plate is 350 N, determine the tensions in the cables at A, B and C. [7]

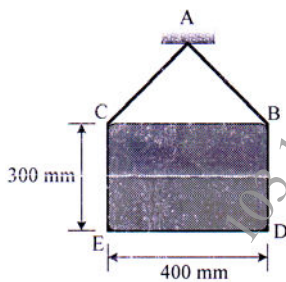

Fig. 1 a

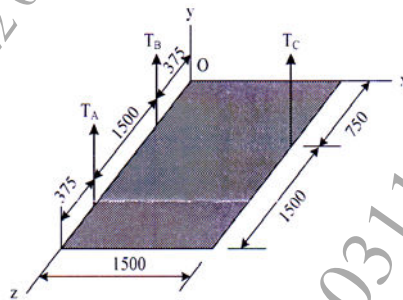

Fig. 1 b

- c) State the component of reaction at roller, hinged, fixed and rocker support. [4]

OR

- Q2)** a) The boom is intended to support two vertical loads, F_1 and F_2 as shown in Fig. 2 a. If the cable CB can sustain a maximum load of 1500 N before it fails, determine the critical loads F_1 and F_2 if $F_1 = 2F_2$. Also determine the reaction at A. [7]

P.T.O.

- b) Three parallel bolting forces act on the rim of the circular plate as shown in Fig. 2 b. Determine the magnitude, nature and point of application of the resultant force with respect to origin O. [7]

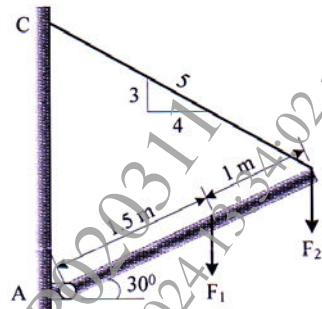

Fig. 2 a

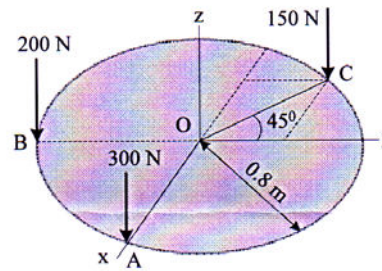

Fig. 2 b

- c) Find support reaction at A and B for the beam AB as shown in Fig. 2 c. [4]

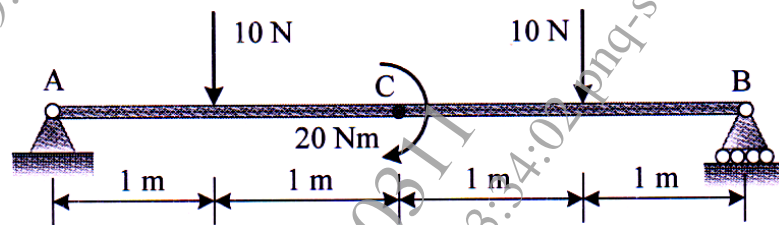

Fig. 2 c

- Q3) a) Identify the zero force members and find forces in the remaining members for the pin jointed truss as shown in Fig. 3 a. [7]

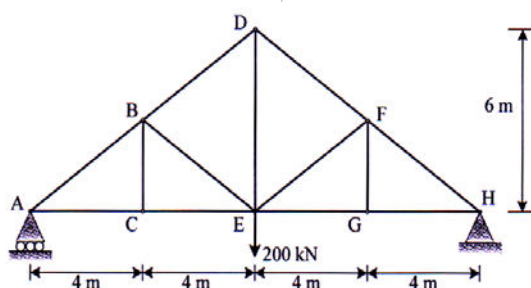

Fig. 3 a

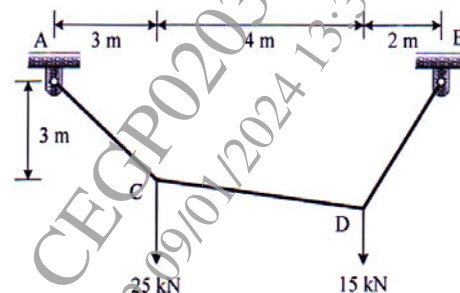

Fig. 3 b

- b) The cable segment supports the loading as shown in Fig. 3 b. Determine the support reactions at A and B. Also find maximum tension in segment of the cable. [7]
- c) Differentiate truss and frame with suitable sketch. [4]

OR

- Q4)** a) Determine the forces in the members CE, BE and BD of the truss as shown in Fig. 3 a. [7]
- b) Determine the components reaction acting on each members AB and BC of a frame as shown in Fig. 4 b. [7]
- c) The maximum tension is 200 N for the cable profiles ABCD as shown in Fig 4 c. Determine the force P at B and C to keep the segment BC in horizontal position. Also find tension in segment BC. [4]

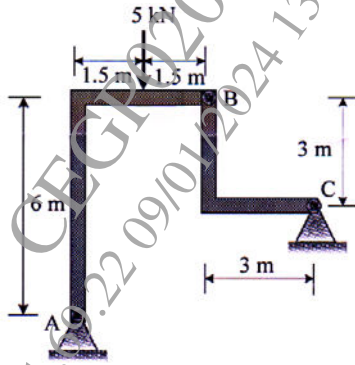

Fig. 4 b

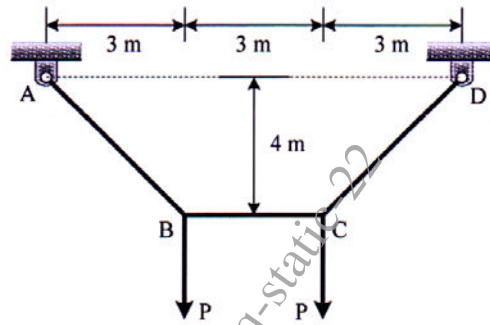

Fig. 4 c

- Q5)** a) A car comes to rest from an initial speed of 80 km/h in a distance of 30 m. With the same constant acceleration, determine the distance 's' for which the car comes to rest from an initial speed. of 110 km/h. [5]
- b) A particle moves along the path $x = (8t^2)$ and $y = (t^3 + 5)$, where x and y is in m and t is in seconds. Determine the magnitude of the particle's velocity and acceleration when $t = 3$ s. [6]
- c) A projectile is launched with a speed of $v_0 = 25$ m/s at an angle of $\theta = 30^\circ$ with horizontal as shown in Fig. 5 c. Determine the maximum distance travel by projectile along horizontal and vertical direction. [6]

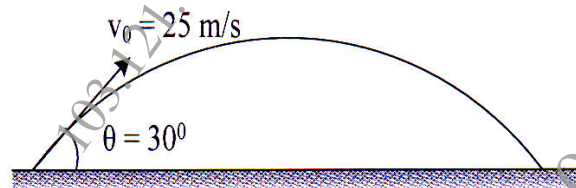

Fig 5 c

OR

- Q6)** a) The motion of a particle is defined by $x = 2t^3 - 15t^2 + 24t + 4$, where x is in m and t is in s. Determine when the velocity is zero and find position at which acceleration is zero. [5]
- b) A car is traveling along a circular curve that has a radius of 50 m. If its speed is 16 m/s and tangential component of acceleration a_t is 8 m/s^2 , determine the magnitude of its total acceleration at this instant. [6]

- c) A projectile is thrown in the air with a speed of 8 m/s and at an angle $\theta = 30^\circ$ with the horizontal, as shown in Fig. 6 c. Determine the horizontal distance it must travel to reach its highest point B. [6]

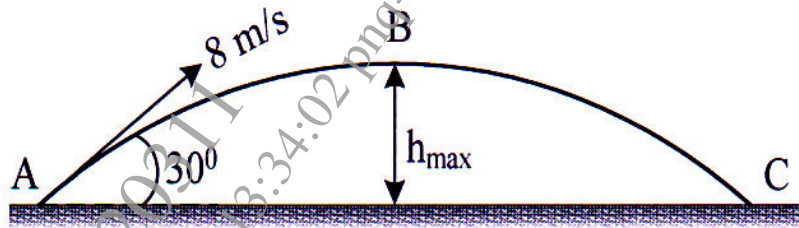

Fig. 6 c

- Q7) a) An 80 kg block rests on a plane as shown in the Fig. 7 a. Find the acceleration with which block slides down using Newton's second law if coefficient of kinetic friction is, $\mu_k = 0.20$. [6]
- b) The pendulum bob has a mass m and is released from rest as shown in Fig. 7 b when $\theta = 0^\circ$. Determine the tension in the cord as function of the angle of descent θ . Neglect the size of bob. [6]

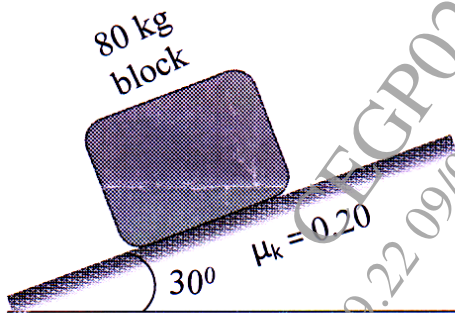

Fig. 7 a

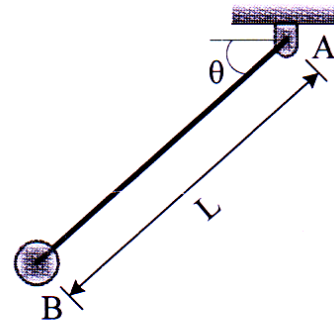

Fig. 7 b

- c) A 20 Mg railroad car moving with 0.5 m/s speed to the right collides with a 35 Mg car which is at rest. If the coefficient of restitution between the two cars is $e = 0.65$, determine the speed of the cars after the collision. [5]

OR

- Q8) a) The system shown in Fig. 8 a is initially at rest. Neglecting axle friction and mass of pulley, determine the acceleration of 200 kg block A. [5]

- b) The man has a mass of 80 kg and sits 3 m from the center of the rotating platform as shown in Fig. 8 b. Due to rotation his speed is increase from rest by $a_t = 0.4 \text{ m/s}^2$. If the coefficient of static friction between the clothes and the platform is $\mu_s = 0.3$, determine the time required to cause him to slip. [6]

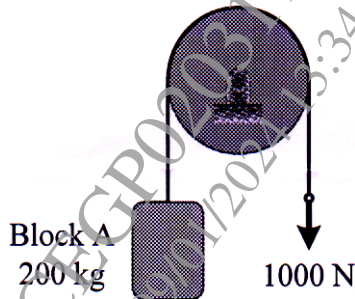

Fig. 8 a

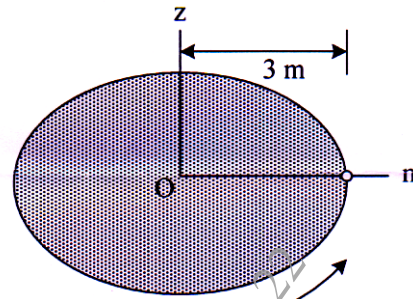

Fig. 8 b

- c) A ball has a mass of 30 kg and is thrown upward with a speed of 15 m/s. Determine the time to attain maximum height using impulse momentum principle. Also find the maximum height. [6]

